

ASSEMBLING INSTRUCTION

CARINA

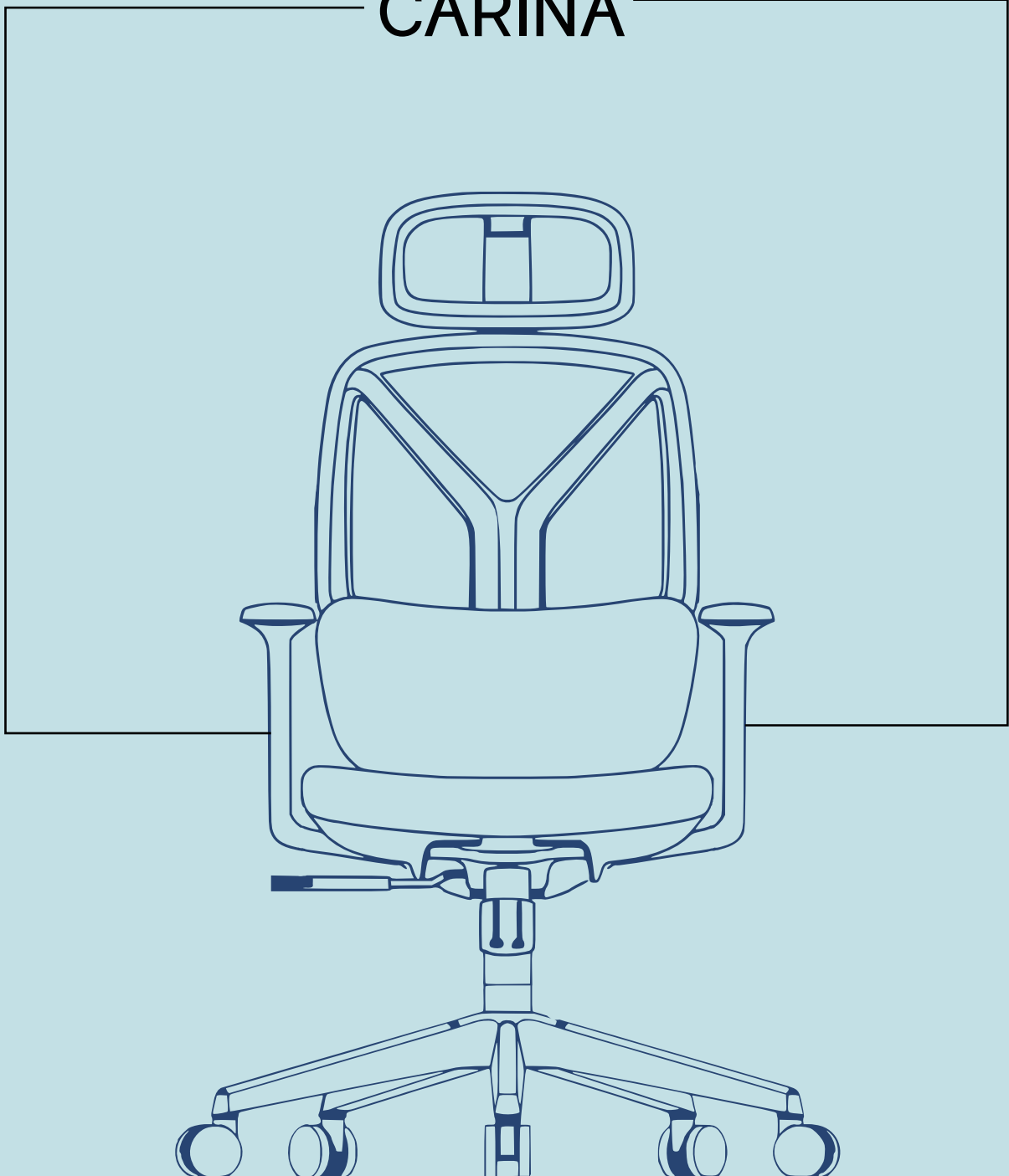

5 PCS of Casters

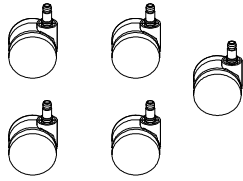

1 PCS of five-star base

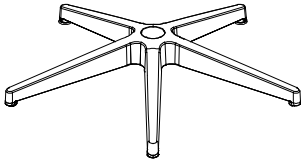

1 PC of Gas Lift



13 PCS of Washers

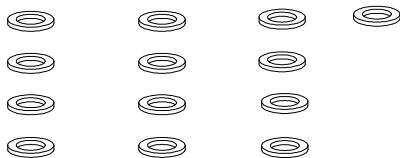

3 PCS of Washers



1 PCS of Assembly Tool(5#)

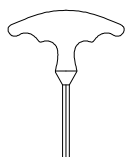

A: 6 PCS of M6*50MM Screws

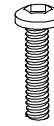

B: 2 PCS of M6*40MM Screws

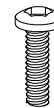

C: 2 PCS of M6*45MM Screws

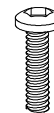

D: 3 PCS of M8*25MM Screws



E: 2 PCS of M6*16MM Screws



Step 1:

Attach the M6*50MM screws (A) with washers to connect the armrests to the chair frame.

A M6*50MM

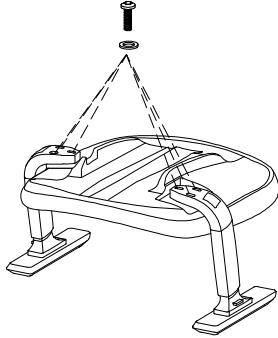

Step 2:

Attach the M6*40MM screws (B) and M6*45MM screws (C) to connect the seat cushion to the chair mechanism.

B M6*40MM

C M6*45MM

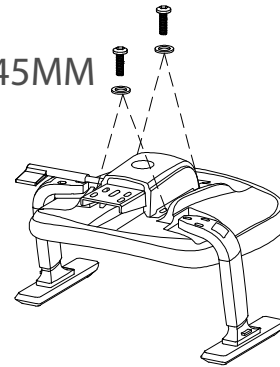

Step 3:

Attach the M8*25MM screws (D) with washers to connect the backrest frame to the base mechanism at the top.

D M8*25MM

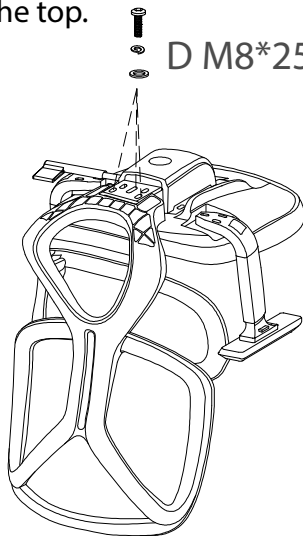

Step 4:

Attach the gas lift to the five-star base as shown in the image.

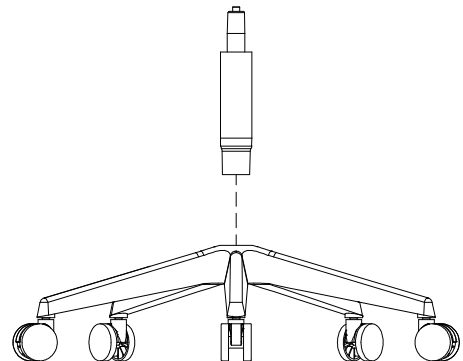

Step 5:

Finally, Use the M6*16MM screws (E) to attach the headrest and Connect the parts from step 3 and step 4 together. ensure all parts are tightened correctly.

E M6*16MM

