

ASSEMBLING INSTRUCTION

DIYA

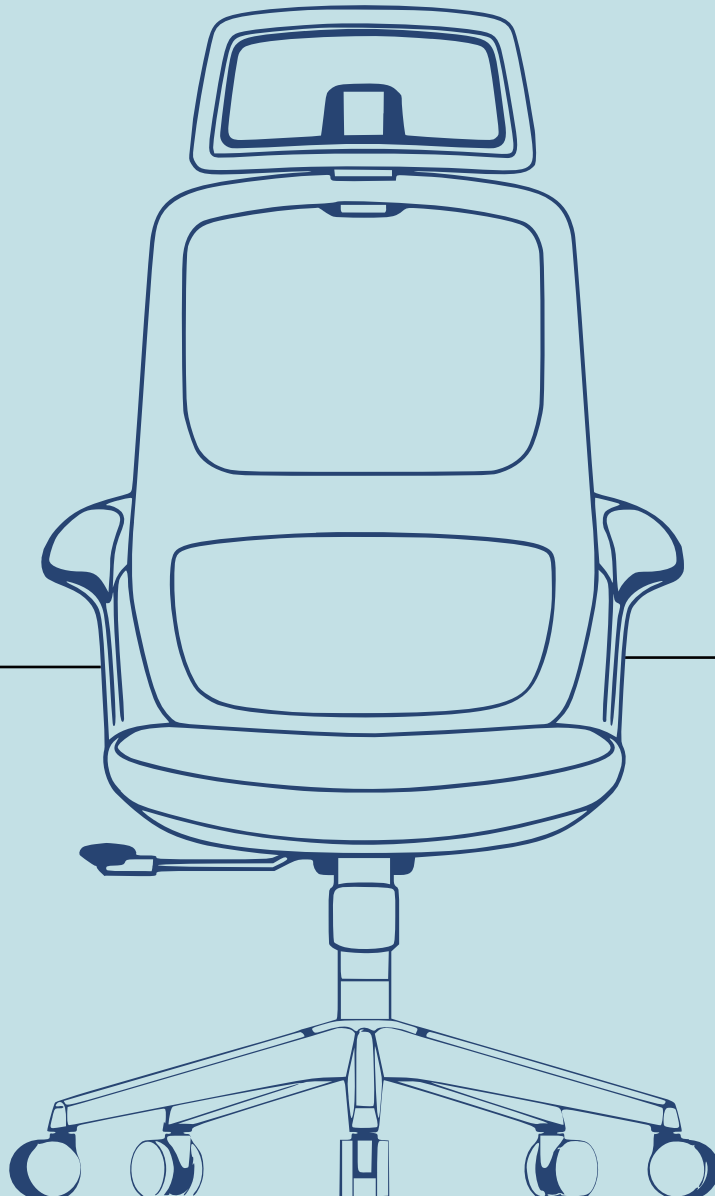

5 PCS of Casters

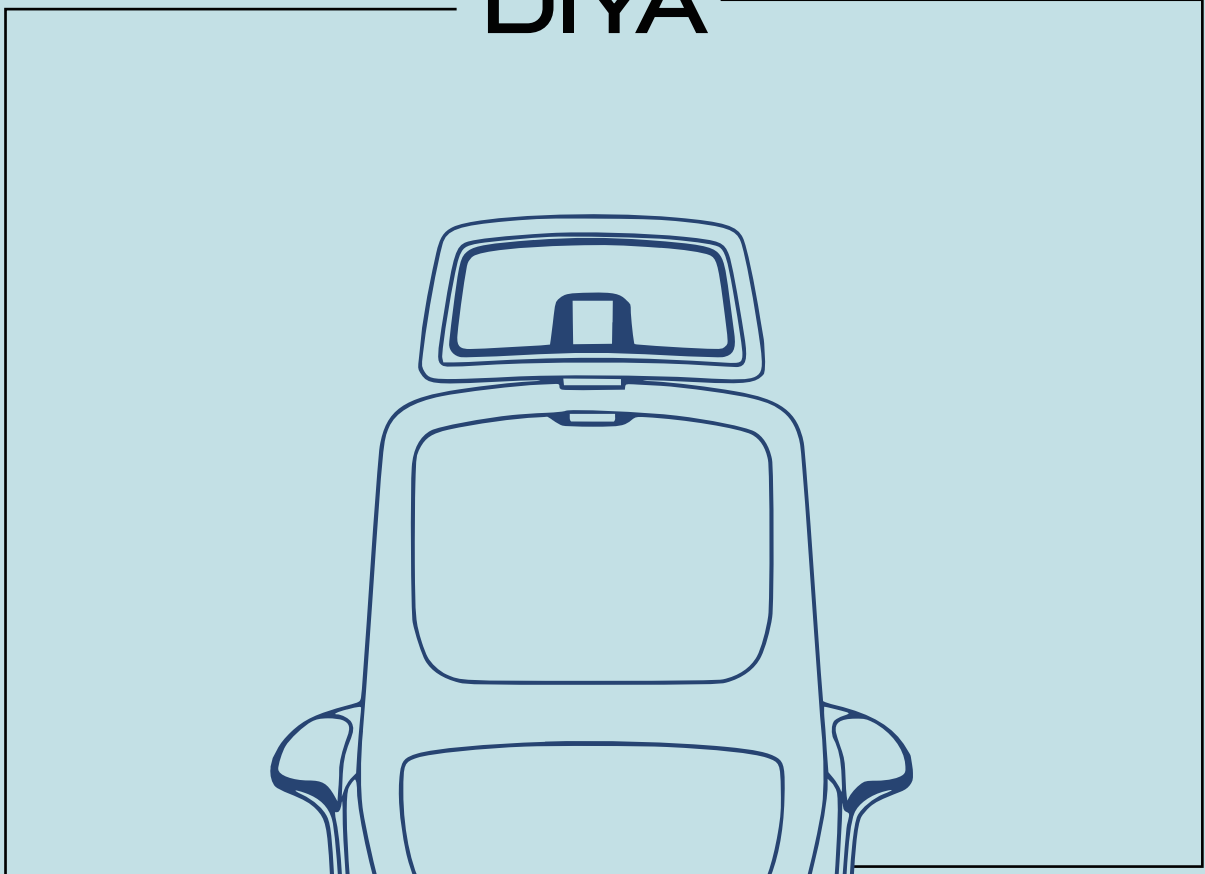
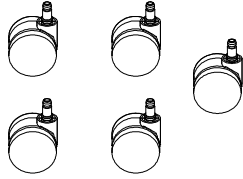

1 PCS of five-star base

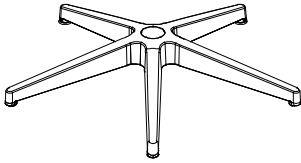

1 PC of Gas Lift



7 PCS of Washers

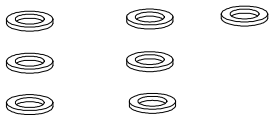

1 PCS of Assembly Tool(4#)



1 PCS of Assembly Tool(5#)

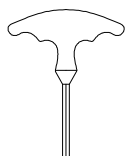

A: 2 PCS of M6*25MM Screws

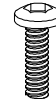

B: 2 PCS of M6*30MM Screws

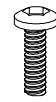

C: 3 PCS of M6*50MM Screws



D: 2 PCS of M4*16MM Screws

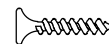

Step 1:

Attach the M6*25MM screws (A) and M6*30MM screws (B) to connect the seat cushion to the chair mechanism.

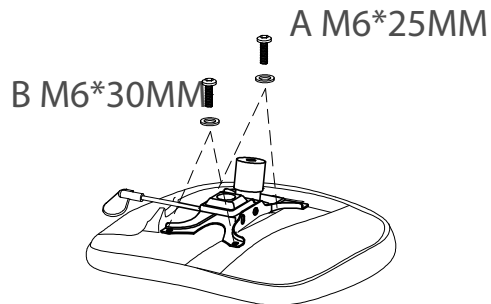

Step 2:

Attach the M6*50MM screws (C) with washers to connect the backrest frame to the base mechanism at the top.



Step 3:

Attach the gas lift to the five-star base as shown in the image.

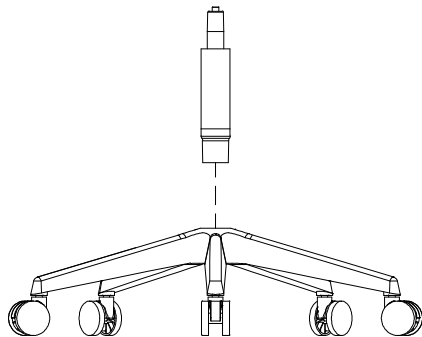

Step 4:

Connect the parts from step 2 and step 3 together

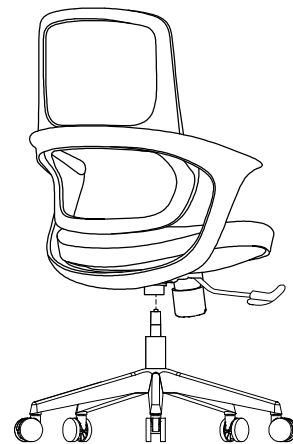

Step 5:

Finally, Use the M4*16MM screws (D) to attach the headrest. ensure all parts are tightened correctly.

