

## ASSEMBLING INSTRUCTION

# SOLENNE

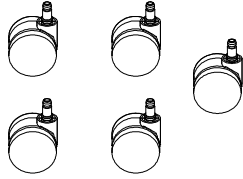

5 PCS of Casters



1 PCS of five-star base

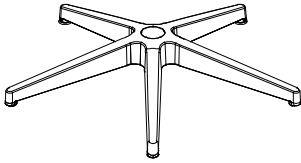

1 PC of Gas Lift



13 PCS of Washers

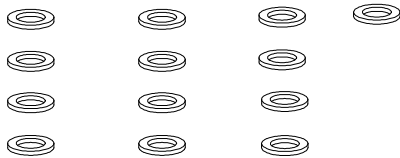

3 PCS of Washers



1 PCS of Assembly Tool(5#)

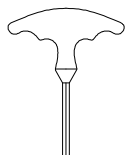

A: 8 PCS of M6\*45MM Screws

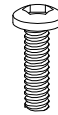

B: 2 PCS of M6\*50MM Screws

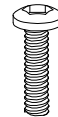

C: 3 PCS of M8\*25MM Screws



### Step 1:

Attach the M6\*45MM screws (A) with washers to connect the armrests to the chair frame.

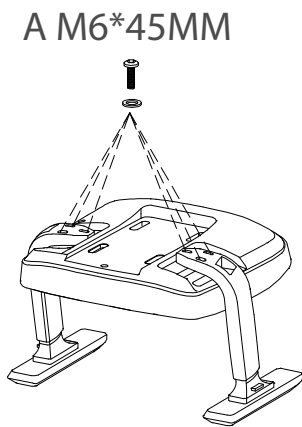

### Step 2:

Attach the M6\*45MM screws (A) and M6\*50MM screws (B) to connect the seat cushion to the chair mechanism.

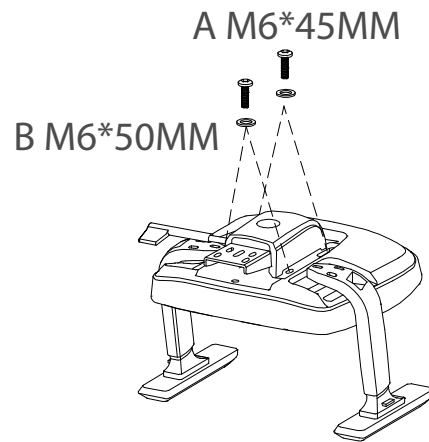

### Step 3:

Attach the M8\*25MM screws (C) with washers to connect the backrest frame to the base mechanism at the top.

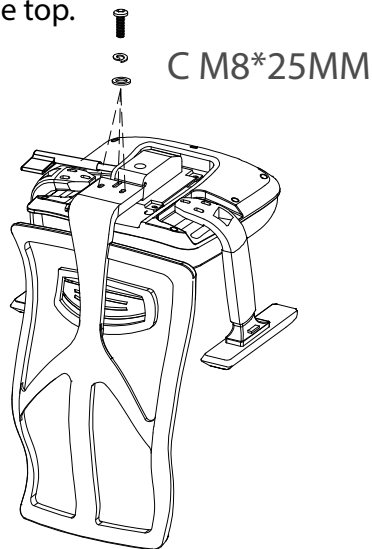

### Step 4:

Attach the gas lift to the five-star base as shown in the image.

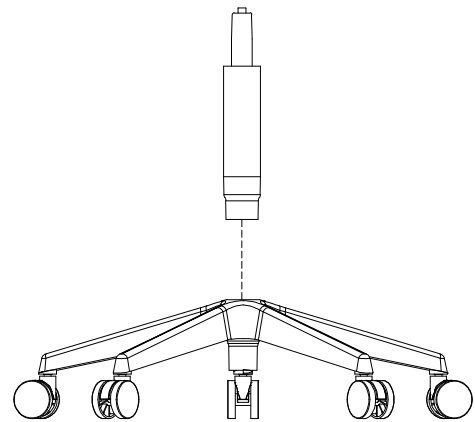

### Step 5:

Finally, Connect the parts from step 3 and step 4 together and ensure all parts are tightened correctly.

